

*Frigidaire*

**INTERNATIONAL**

## Factory Parts Catalog

Product No.	FGTD20V4CWB
Series	134A SYSTEM
Color	white
Volts	220
Wiring Diagram	240583901
Owner's Guide	240432700
Market	Export
Energy Guide	240460365
Service Data Sheet	240586202
Installation Instructions	240568301

INTERNATIONAL  
3 Parkway Center, Pittsburgh, PA 15220

Publication No.  
**5995455259**  
05/12/05  
(EN/SERVICE/KHB)  
390

### **TOP-MOUNT REFRIGERATOR**

Model No.  
**FGTD20V4C**

Copyright © 2005 Electrolux Home Products, Inc.  
All rights reserved.

**DOOR**

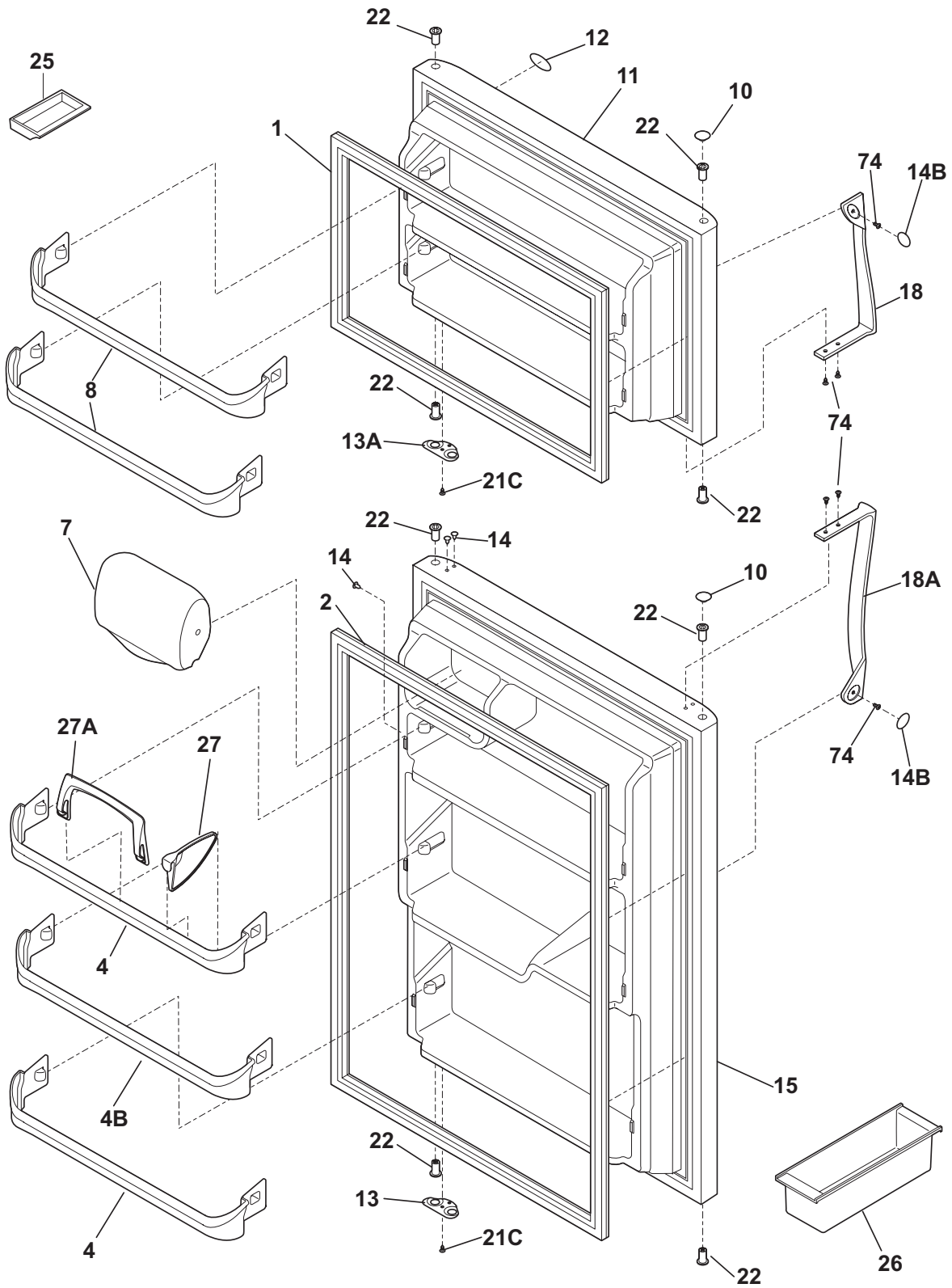

N05DCDCKA2

## DOOR

---

POS. NO	PART NO.	DESCRIPTION
1	240542115	Gasket-frzr door, white, magnetic
2	240542118	Gasket-refr door, white, magnetic
4	240534901	Rack-door
4B	240534701	Rack-door, 4B
7	240337703	Door-dairy, w/o graphics, clear
8	240534801	Rack-door
10	240381301	Plug-button, white, hinge brg hole, (2)
11	240409901	Door-frzr, white, complete assy
12	240589601	Label-nameplate
13	240312403	Door Stop, white, ref
13A	240312404	Door Stop, white, frzr
14	240494001	Plug-button, white
14B	240383601	Plug-button, white, door handle
15	240410001	Door-refr, white, complete assy
18	240339201	Handle-door, white, refr-LH/frzr-RH
18A	240339206	Handle-door, white, refr-RH/frzr-LH
21C	218252200	Screw, #8 truss hd, 10-32CA x 0.500
22	240527101	Bearing-hinge, natural color
25	5308000716	Dish, butter
26	3204522	Container, egg
27	240396302	Snugger, paddle type
27A	240396102	Retainer, tall bottle
74	240383401	Screw, truss hd quad, #10-16 x .500

**CABINET**

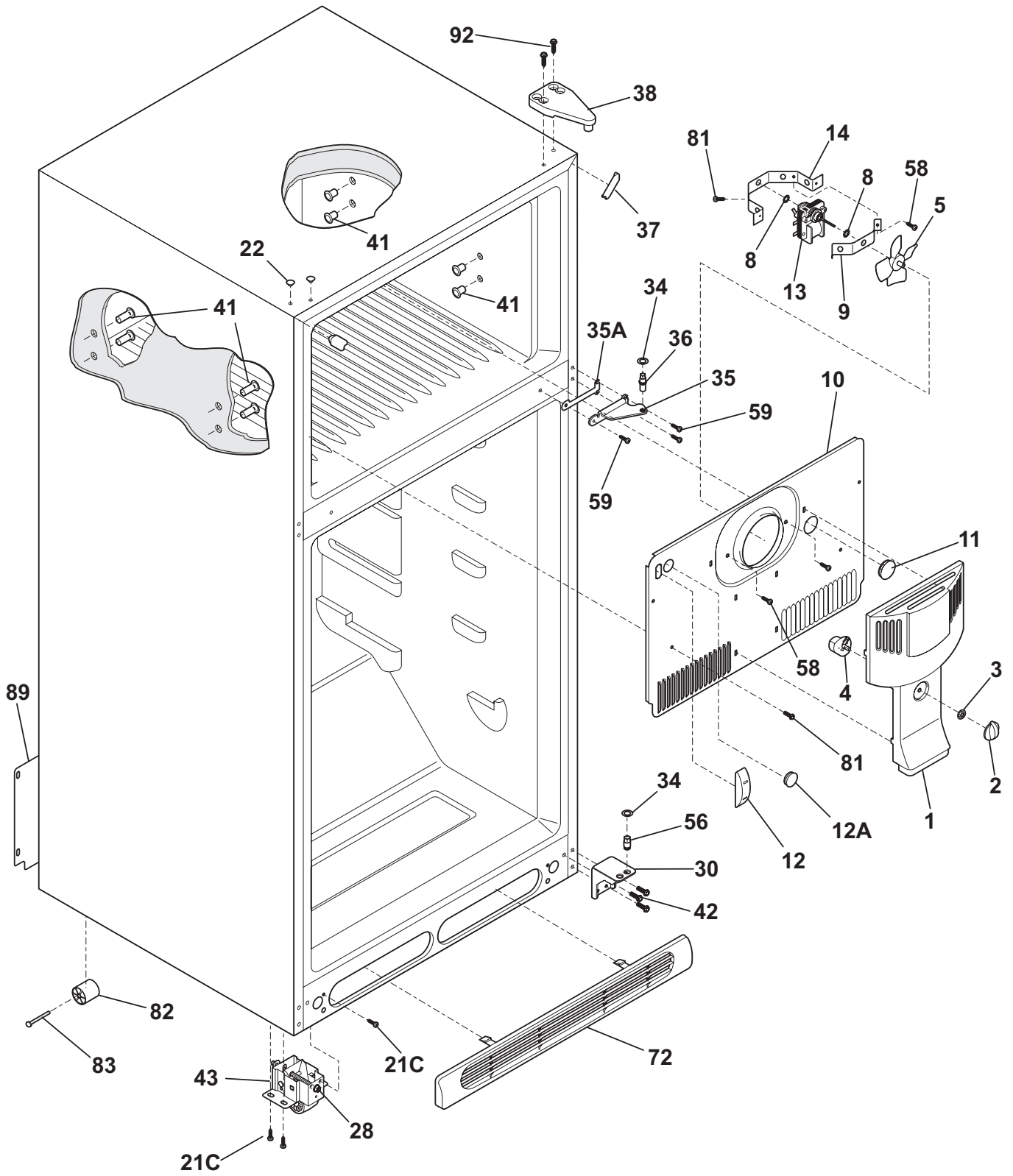

**N05BBAABA22**

## CABINET

---

POS. NO	PART NO.	DESCRIPTION
1	241652301	Cover-fan
2	240367001	Knob-damper control
3	5303001028	Nut, push-on
4	240367401	Damper-fan cover
5 #	5308000010	Fan Blade, red, evaporator fan
8	5300157666	Bushing-motor mtg, (2)
9	5303292396	Bracket-motor mtg, front
10	241652210	Cover-evap coil
10*	240568601	Seal-coil cover
10*	241520701	Harness-wiring, freezer
11	5303208309	Plug-hole, factory test
12	241557601	Plug-ice maker harness, rectangular
12*	218843800	Screw, hex wshr hd, 8-15A x 0.500
12A	240374401	Plug-wtr inlet tube, round, 1"
12A*	241586701	Plug-foam-wtr-inlet, round
13 #	240419702	Motor, evaporator fan, 220/240 V
13*	215474201	Washer, "slinger", nylon, evap fan shaft
13*	218931001	Clamp-motor wiring, nylon, w/adhesive tape
14	5303292397	Bracket-motor mtg, rear
14*	240433202	Screw, hex washer head, 8-18 x 5/16
21C	218252200	Screw, #8 truss hd, 10-32CA x 0.500
22	215774901	Plug-button, white, upr hinge holes
28	240335501	Bolt-roller adj, hex washer head, 1/4-20 x 4.020, (2), special
30	240314002	Bracket-lower hinge, white
34	240311301	Washer, hinge, nylon, (2)
35	240313801	Bracket-ctr hinge, zinc
35A	240336802	Spacer-hinge, center
36	240516401	Pin-center hinge
37	241611301	Trim-cabinet corner, white, (2)
38	241622601	Bracket-upper hinge, plastic, white
41	5308009759	Grommet, shelf mtg, 1.25", LH, (4)
42	240578901	Screw-hinge mtg, hex head, 1/4-20 x 5/8
43	240335003	Roller Assy, adjustable, front, (2)
56	240516501	Pin-lower hinge
58	218897002	Screw, hex washer head, 8-32 x 0.375
59	240442701	Screw-#10-32 X 3/4, zinc
72	240368205	Grille/Kickplate, white
81	5308016566	Screw, hex washer head, 8-15A x 0.625, low profile
82	5304418225	Roller, compressor base, rear, (2)
83	5303316859	Rivet, flat head, 1/4 OD x 1-3/4, roller pin
89	240326119	Cover-access, with label
89*	241500302	Screw, hex washer head, 8-18AB x 0.625
92	241624301	Screw-hinge mtg, hex head, 1/4-20 x 1.00
*	5303305324	Paint, touch-up, white

**SHELVES**

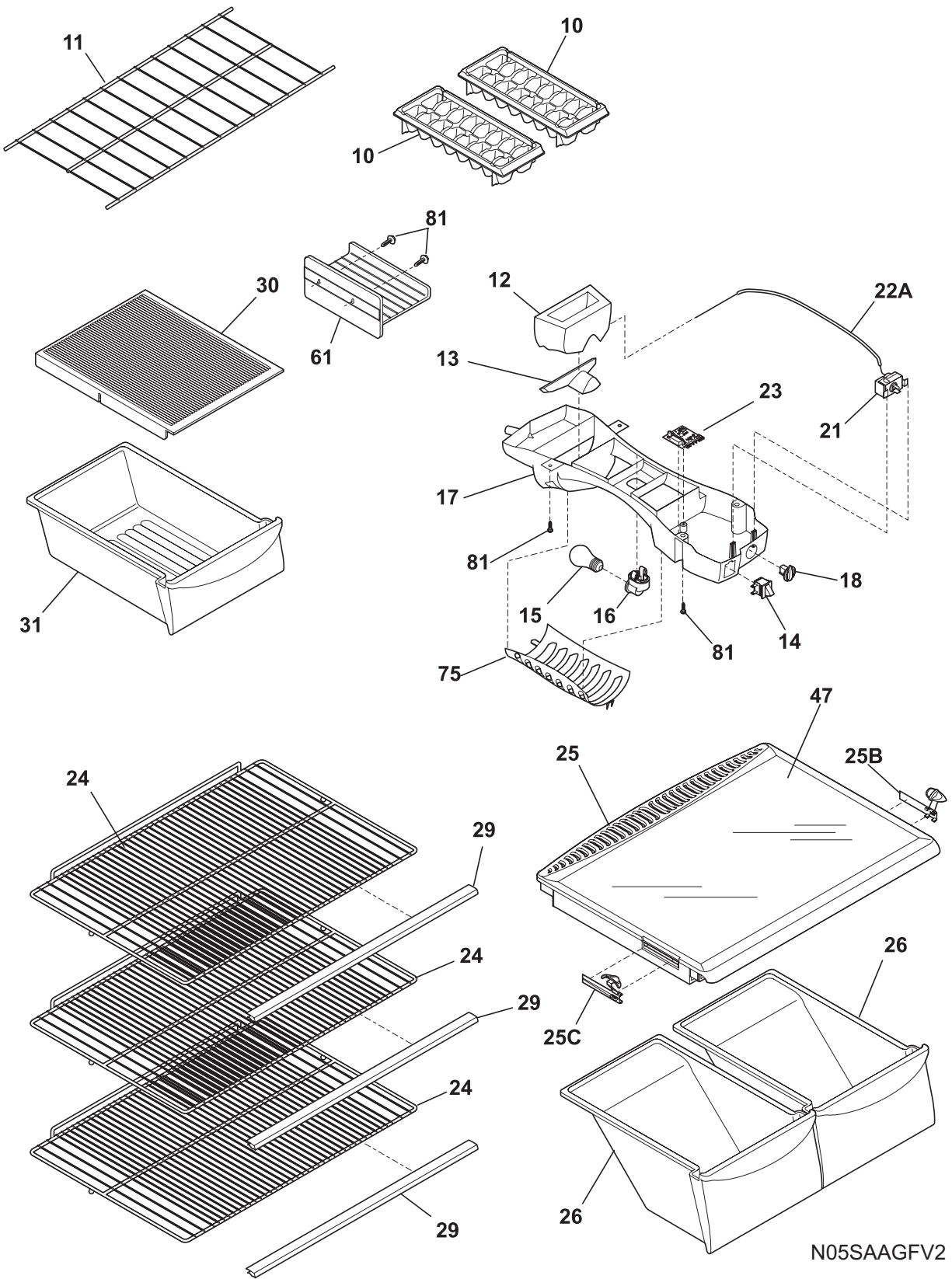

N05SAAGFV2

## SHELVES

---

POS. NO	PART NO.	DESCRIPTION
10	215667501	Tray, ice cube, plastic
11	240358005	Shelf, freezer, full-width, wire
12	240545001	Diffuser, air, top
13	240362601	Diffuser, air, bottom
14	241554901	Switch-light/lamp
15	218814400	Light Bulb/Lamp
16 #	240433702	Socket-light/lamp
17	240352701	Control Box
17*#	240375501	Wiring Harness, control box
18	240360801	Knob, temp control
21 #	5304422638	Control, temperature
22A	240468201	Tube, sensor sleeve, 31 inch, plastic, white
23 #	240545402	Control-defrost, adaptive timer, 220/240 V, PC board
23*	5303001259	Screw-timer mtg, pan hd, 6-20 x 0.438, (2)
24	240360905	Shelf, sliding, wire
25	240364714	Cover-crisper pan
25B	241613501	Control-humidity, RH
25C	241613502	Control-humidity, LH
26	240337107	Pan-crisper, clear, (2), no graphics
29	240430708	Trim-shelf
30	240361801	Cover, meat pan hanger, drop through
31	240530810	Pan, meat bin
47	240350643	Insert-pan cover, glass
61	215781501	Shelf, ice tray mount, wire
75	240412701	Shield, light
81	5308016566	Screw, hex washer head, 8-15A x 0.625, low profile

**SYSTEM**

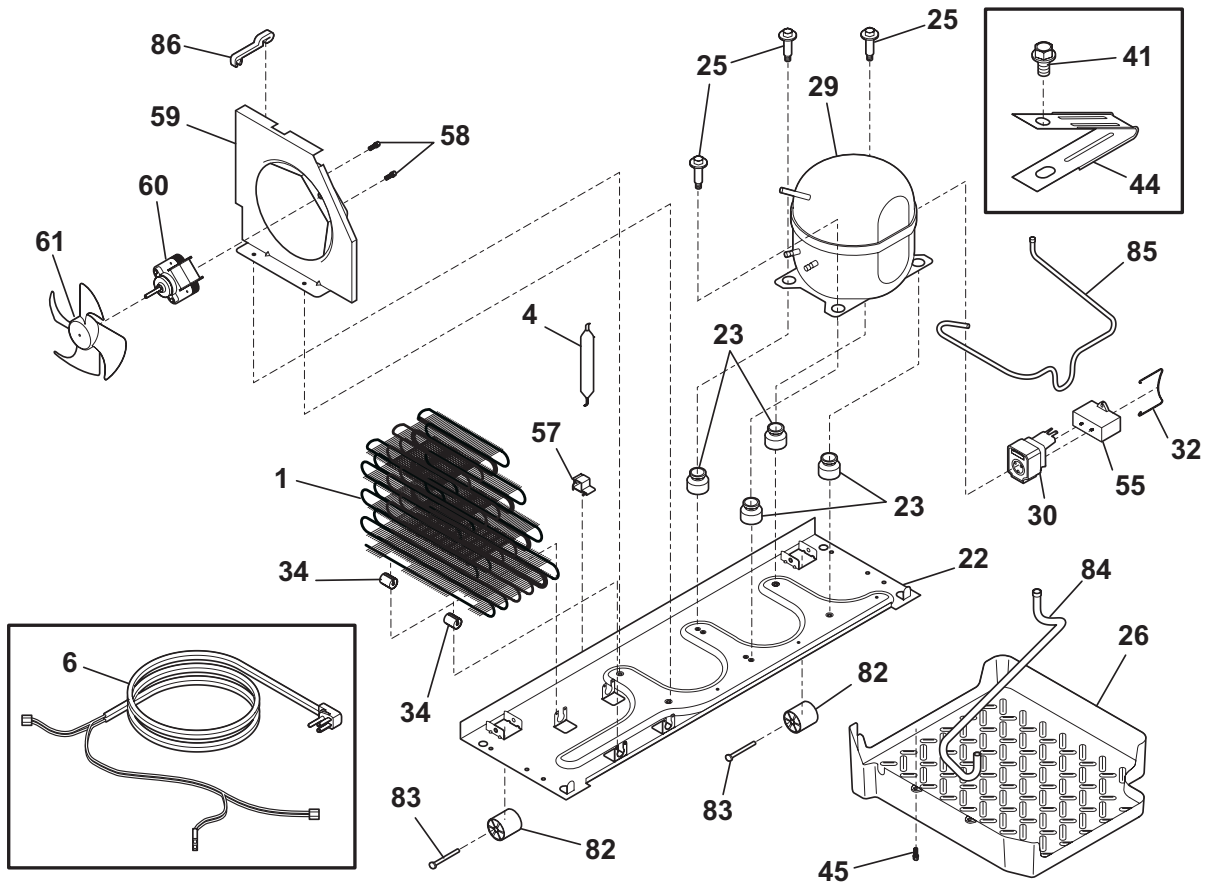
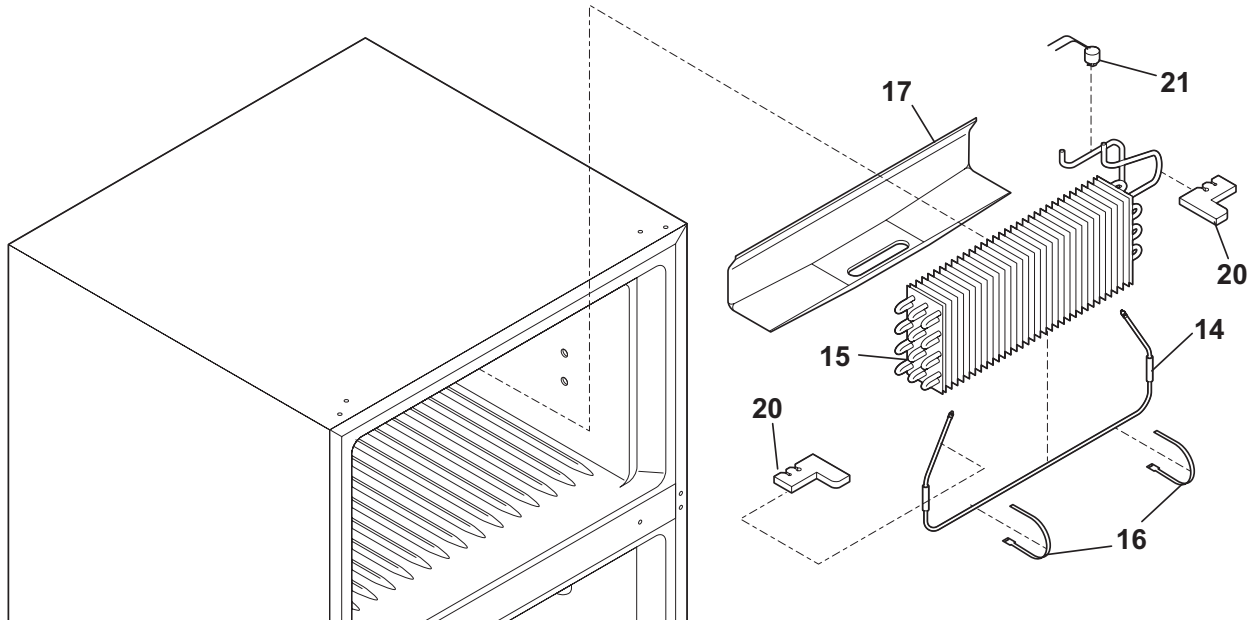

N05CAAAA19



## SYSTEM

---

POS. NO	PART NO.	DESCRIPTION
1	241665701	Condenser, dynamic
4 #	218944001	Drier-filter, R134a System
6 #	240449501	Cord-electric power
6*	240447101	Bracket, strain relief
6*	240447201	Clamp, strain relief
6*	240451501	Screw, ind hex wshr hd, 8-32 x 0.375, thread rolling
6*	241520701	Harness-wiring, freezer
6*	241626401	Harness-wiring, machine compt
6* #	240375501	Wiring Harness, control box
14 #	240356216	Defrost Heater, 220 V
15 #	5303918274	Evaporator Kit
16	5308000110	Strap-evap/heater, aluminum, (2)
17	241551801	Trough-drain
20	241551901	Insulation Block
21 #	5303918202	Thermostat-defrost, kit
22	241665501	Base-compressor
22*	218252200	Screw, #8 truss hd, 10-32CA x 0.500
23	218513300	Grommet-compr mtg, (4)
25	240491501	Screw-compressor mtg, 1/4-28 x 1.16, shoulder, typ CF
26	240332608	Pan-defrost drain
29 #	5303918318	Compressor, w/electricals
30	241524610	Starter-PTC
32	240553401	Clamp, elec cont mtg, compressor
34	240405201	Grommet, rubber, black, cond tube/wire
41	240433202	Screw, hex washer head, 8-18 x 5/16
44	5303001199	Clamp-wiring harness, strain relief, galv steel
45	5308016566	Screw, hex washer head, 8-15A x 0.625, low profile
55 #	218909908	Capacitor, run
55*	218897001	Screw, hex washer head, 8-32 x 1/4
57	240542601	Clip-wiring harness
58	218897002	Screw, hex washer head, 8-32 x 0.375
59	5304430246	Bracket-cond motor assy
59*	240346701	Tape-foam seal, shroud
59*	240359401	Screw-fan shroud, (2)
60 #	240525403	Motor-condenser fan
61 #	240524101	Fan Blade, galv steel, condenser fan
82	5304418225	Roller, compressor base, rear, (2)
83	5303316859	Rivet, flat head, 1/4 OD x 1-3/4, roller pin
84	240359601	Tube-drain, lower
85	240346201	Tube-connector, suction
85	240553501	Tube-connector, suction
86	240409302	Spacer-cond tube, black
* #	5303918263	Heat Exchanger Kit, suction line
*	5303918241	Hot Tube Repair Kit, 220 V, service

### WIRING SCHEMATIC

240398601

NOTE:  
- - - - - DENOTES NOT ON ALL MODELS.

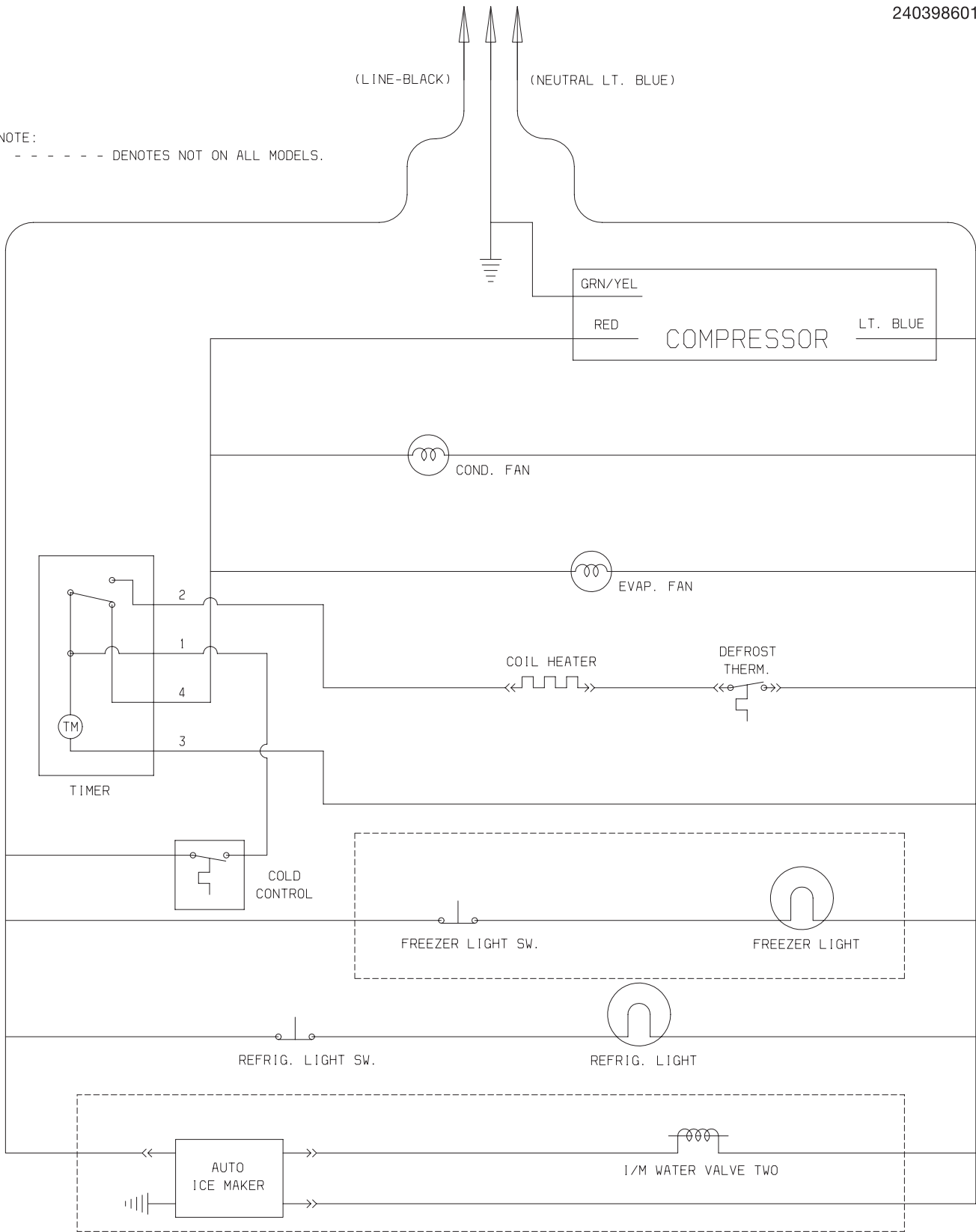

### WIRING DIAGRAM

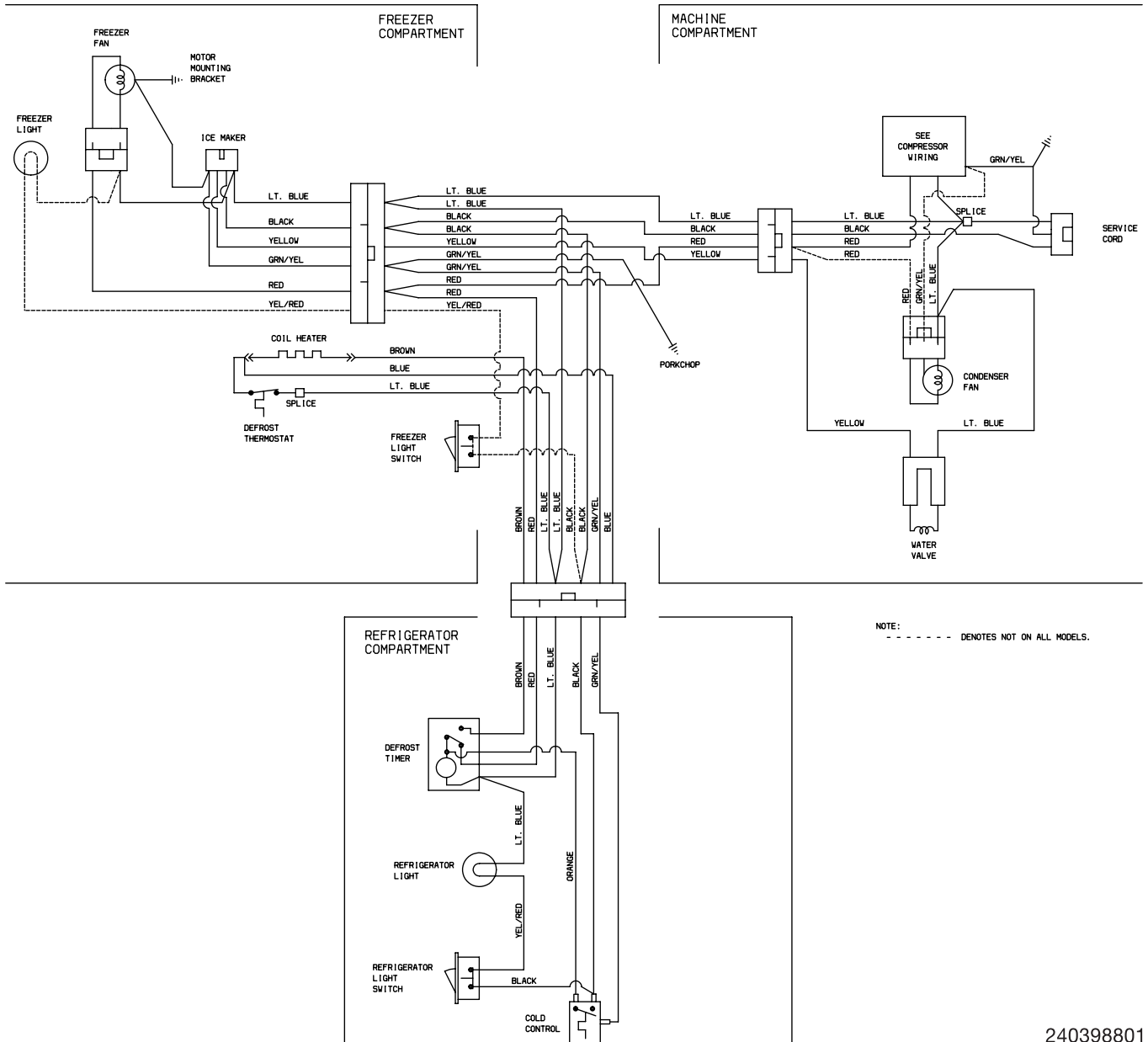

240398801